

XG Category 6A AMP-TWIST JACK

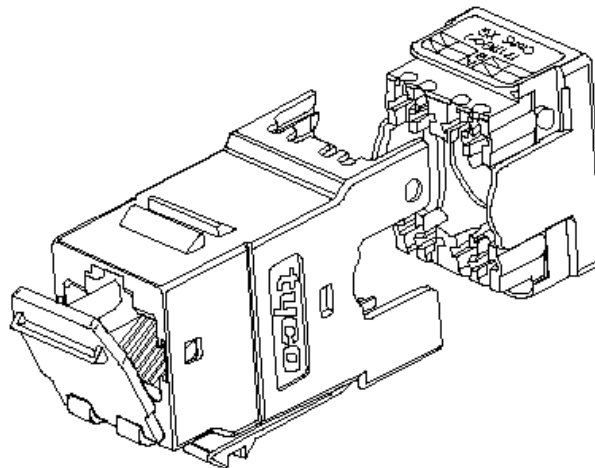

1711342-1, 1711160-1, 1711343-1, 1711295-1



Description

AMP NETCONNECT XG Category 6A Shielded AMP-TWIST modular jacks meet or exceed channel specifications of ANSI/TIA/EIA-568-B.2-10 Category 6A and ISO/IEC 11801:2002/Amd 1:2008 Class EA up to 500 MHz when used as a component in a properly installed AMP NETCONNECT XG F/UTP channel. The AMP NETCONNECT XG Category 6A F/UTP System complies with all of the performance requirements for current and proposed applications such as Gigabit Ethernet (1000BASE-Tx), 10/100BASE-Tx, token ring, 155 Mbps ATM, 100 Mbps TP-PMD, ISDN, analog and digital video, analog and digital voice (VoIP), and exceeds all requirements for IEEE 802.3an 10 Gigabit Ethernet on all parameters.

AMP NETCONNECT XG Category 6A modular jacks are shielded, have a slim profile and are compatible with SL Series and standard faceplates. Universal wiring labels permit termination to either T568A or T568B wiring patterns. These modular jacks are available with integral dust covers and back (180°) or side (90°) cable entry. XG Category 6A shielded modular jacks include an integrated lacing fixture for use with the SL Series modular jack termination tool (1725150) for extremely fast terminations that are consistent and repeatable. The modular jacks contain integrated cutting blades used during termination to eliminate the need to manually trim conductors and to allow all four pairs of a four pair cable to be terminated at one time. XG Category 6A Shielded AMP-TWIST modular jacks feature a robust, die-cast metal body which creates an integral shield.

Specification (text in brackets [] requires a choice)

Modular jacks shall be unkeyed, 4-pair, RJ-45, with an integrated shield and shall fit in a .790" X .582" opening. Modular jacks shall terminate using the AMP NETCONNECT SL Series modular jack termination tool part number 1725150-3 (or 1725150-1 after removing the tool's lacing fixture), and be color-coded for both T568A and T568B wiring. Each jack shall contain integrated cutting blades to automatically trim conductors during termination. Each modular jack shall be wired to **[T568A or T568B]** and shall accommodate cable with a maximum O.D. of 9.00 mm. Cables shall enter the jack at **[180°, 90° from the right or 90° from the left]**. The insulation displacement contacts shall be capable of terminating 24-22 AWG solid or 26-24 AWG stranded conductors with a maximum insulation diameter of 1.60 mm. The insulation displacement contacts shall be paired, with additional space between pairs to improve crosstalk performance. Modular jacks shall utilize a secondary PC board, separate from the signal path, for crosstalk compensation. Each modular jack shall meet the TIA/EIA-568-B.2-10, Category 6A performance standards and the requirements listed in the following table.

[Include Performance Characteristics table from page 2]

Modular Jacks shall be independently tested for performance to the following specifications:

1. ANSI/TIA/EIA-568-B.2-10
2. ISO/IEC 11801:2002/Amd 1:2008
3. IEEE 802.3an

[Each jack shall incorporate an integral, hinged dust cover.] Modular jacks shall be AMP NETCONNECT part number **[1711160-1, 1711342-1, 1711343-1 or 1711295-1]**.

Part Numbers

Description	Form Factor	TIA/EIA Category [ISO Class]	Rear Cable Entry	Accessories	Part Numbers
XG AMP-TWIST Shielded Modular jacks	SL Series	6A [EA]	180°(back)	-	1711342-1
				Dust Cover	1711160-1
			90°(side)	-	1711343-1
				Dust Cover	1711295-1

XG Category 6A AMP-TWIST JACK



1711342-1, 1711160-1, 1711343-1, 1711295-1

Channel Performance Characteristics (meet or exceed ANSI/EIA/TIA, ISO/IEC and IEEE requirements)

Frequency (MHz)	Insertion Loss (dB)	NEXT (dB)	PSNEXT (dB)	ACRF (dB)	PSACRF (dB)	Return Loss (dB)	Prop Delay (ns/100m)	Prop Delay Skew (ns)	TCL (dB)	ELTCL / TCTL (dB)	PSANEXT (dB)	PSAACRF / PSAFEXT (dB)
0.772	2.1	65.0	62.0	65.5	62.5	19.0	585.0	50.0	40.0	32.2	67.0	67.0
1	2.3	65.0	62.0	63.3	60.3	19.0	580.0	50.0	40.0	30.0	67.0	67.0
4	4.2	63.0	60.5	51.2	48.2	19.0	562.0	50.0	40.0	18.0	67.0	65.0
8	5.8	58.2	55.6	45.2	42.2	19.0	556.7	50.0	39.5	11.9	67.0	58.9
10	6.5	56.6	54.0	43.3	40.3	19.0	555.4	50.0	38.0	10.0	67.0	57.0
16	8.2	53.2	50.6	39.2	36.2	18.0	553.0	50.0	34.9	5.9	67.0	52.9
20	9.2	51.6	49.0	37.2	34.2	17.5	552.0	50.0	33.5	4.0	67.0	51.0
25	10.2	50.0	47.3	35.3	32.3	17.0	551.2	50.0	32.0	2.0	66.0	49.0
31.25	11.5	48.4	45.7	33.4	30.4	16.5	550.4	50.0	30.4	N/A	65.1	47.1
62.5	16.4	43.4	40.6	27.3	24.3	14.0	548.6	50.0	24.4	N/A	62.0	41.1
100	20.9	39.9	37.1	23.3	20.3	12.0	547.6	50.0	20.3	N/A	60.0	37.0
200	30.1	34.8	31.9	17.2	14.2	9.0	546.5	50.0	14.3	N/A	55.5	31.0
250	33.9	33.1	30.2	15.3	12.3	8.0	546.3	50.0	12.3	N/A	54.0	29.0
300	37.4	31.7	28.8	13.7	10.7	7.2	546.1	50.0	10.8	N/A	52.8	27.5
400	43.6	28.7	25.8	11.2	8.2	6.0	545.8	50.0	8.3	N/A	51.0	24.9
500	49.3	26.1	23.2	9.28	6.3	6.0	545.6	50.0	6.3	N/A	49.5	23.0

Technical Details

Materials	
Modular Jack and Lacing Fixture Housing –	Zinc Alloy
IDC Connecting Block –	Polycarbonate, 94V-0 rated
Contacts –	Beryllium copper, plated with 1.27 µm [50 µin] thick gold in localized area and 3.81µm [150 µin] minimum thick nickel under plate and 3.8 µin minimum thick tin-lead in solder area over 1.27 µm minimum thick nickel under plate
Cutting Blade and Shield Point Contact –	Stainless Steel
Insulation Displacement Contacts –	Phosphorous bronze, plated with 3.81 µm [150 µin] minimum thick matte tin over 1.27 µm [50 µin] minimum thick nickel under plate
Integral Dust Cover –	Polycarbonate
Electrical Characteristics	
Voltage –	150VAC max.
Operating Temperature –	-40° to 70°C (-40° to 158°F)
Mechanical Characteristics	
Modular Jack –	750 mating cycles
Insulation Displacement Contacts –	Accept solid, 24-22 AWG conductors or stranded 26-24 AWG conductors with a maximum insulation diameter of 1.60 mm
Cable Outside Diameter –	Accepts cables with a maximum O.D. of 9.00 mm
Approval	
	RoHS Compliant

Specifications subject to change without notice. Revised 02/10

<http://www.ampnetconnect.com/thailand>

